

Plastic Snap-on Chains with rubber top and bearings

1873 series

- Main application in spiral conveyors.
- Plates material: POM; color coffee
- Base chain: 12A roller chains, Material: CS or SS
- Max speed: 50m/min lubrication, 30m/min dry
- Working load: 3200N (mat.: CS), 1600N (mat.: SS)
- Max conveying length: 30m (mat.: CS), 24m (mat.:SS)
- Supply unit: 1.524mtr(5ft)
- Rubber material: TPE, TPE hardness: 65 ± 5 ;

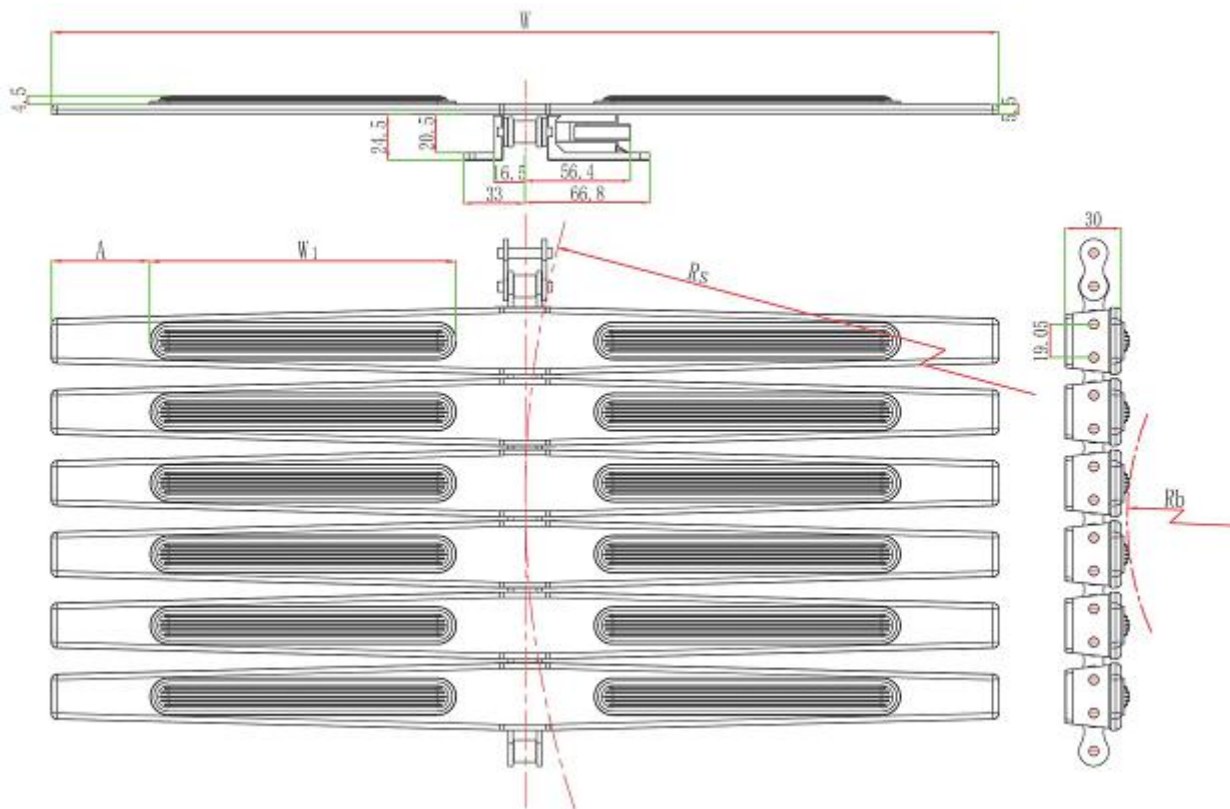

sprocket P401



parts P306-332



wear strip P355-359



chain guide P343-354

| Code | | W width (mm) | W1 width | A width | Weight (Kg/m) | Backflex R (mm) | Min.Radius (mm) |
|----------------|------------------|-----------------|-------------|---------|------------------|--------------------|--------------------|
| CS | SS | | | | | | |
| HF1873-K1200-Z | HF1873SS-K1200-Z | 304.8 | 114.2 | 26.1 | 5.5 | 150 | 610 |
| HF1873-K1600-Z | HF1873SS-K1600-Z | 406 | 114.2 | 51.9 | 6 | 150 | 610 |
| HF1873-K2000-Z | HF1873SS-K2000-Z | 508 | 164.2 | 52.7 | 6.5 | 150 | 610 |